

# 551527-LS01-3 LOW MOUNT PASSENGER SIDE BELT TENSIONER KIT



Made in the USA  
with USA made materials,  
metric flange bolts, spacers,  
pulleys, & tensioners

Scan to visit our web site



www.ictbillet.com

Technical  
Support

www.ictbillet.com  
email: sales@ictbillet.com  
Phone: 316-300-0833

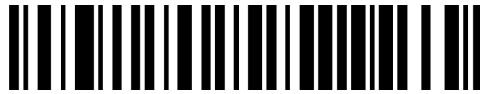

840117202023



**! WARNING: Cancer and Reproductive Harm - www.P65Warnings.ca.gov**

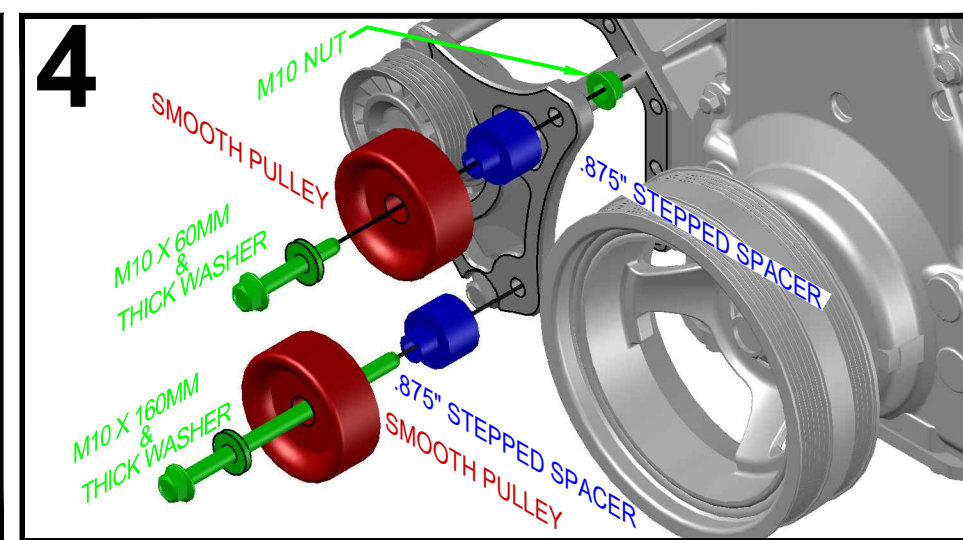
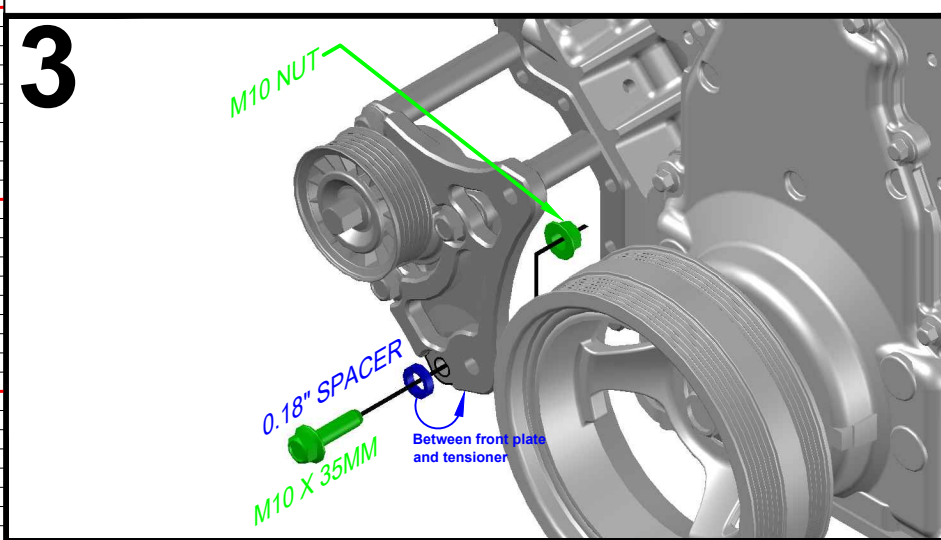
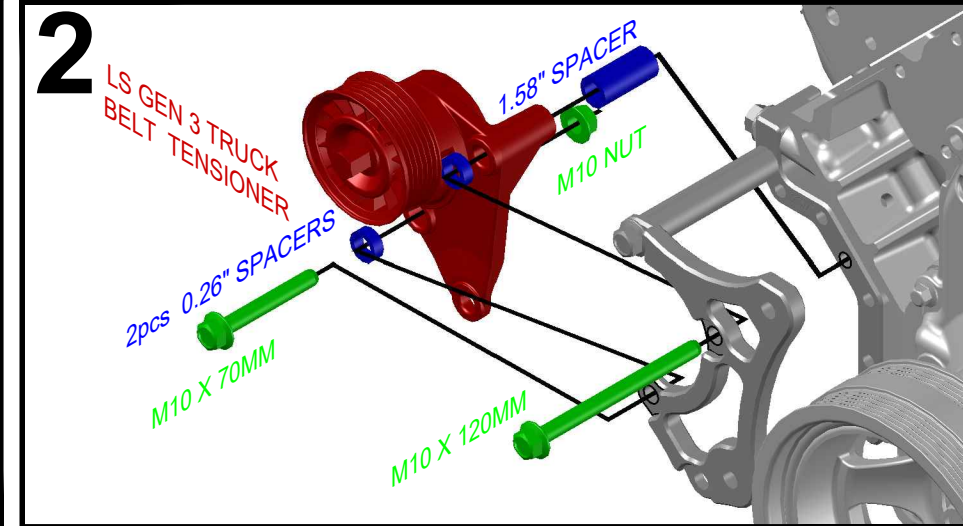
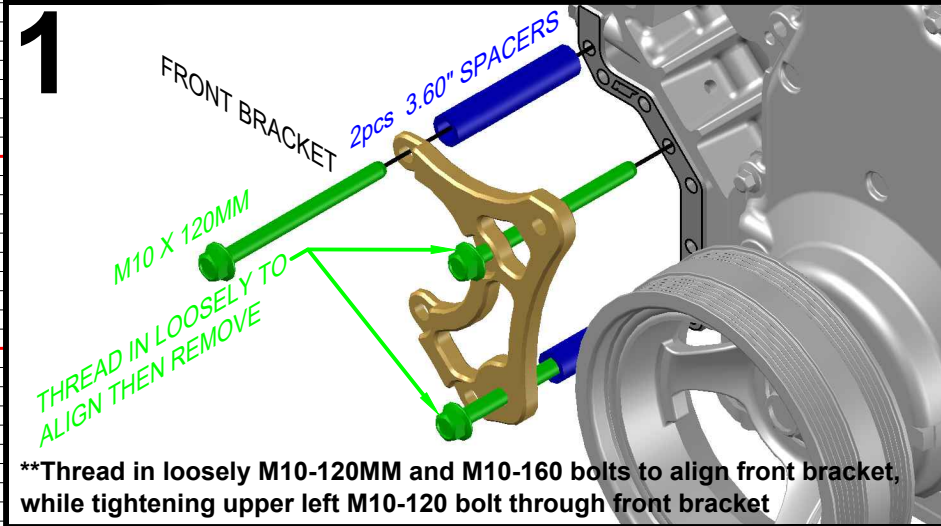

**! WARNING: Proposition 65 - This product can expose you to chemicals including lead, which is known to the State of California to cause cancer, birth defects, or other reproductive harm. For more information go to www.P65Warnings.ca.gov**

**ALUMINUM** - Most of the aluminum alloys used today contain some level of lead, usually less than .1%. Lead is known to the state of California to cause cancer and reproductive harm. Most aluminum alloys are physiologically inert in their solid form, and the lead is contained within, however user-generated dust and/or fumes may pose a hazard if inhaled or ingested. Heating beyond a certain temperature may also provide avenues for exposure.

**STEEL BOLTS** - Steel is an iron alloy with several metals including Nickel and Chromium. Both Nickel and Chromium are known to the State of California to cause cancer and reproductive harm, respectfully. This warning applies to stainless steels as well.

